

# **BATIS**

BATTERY



ISO 9001  
ISO 14001  
BS OHSAS 45001

## Sepahan Battery Industrial Complex (SBIC)

Was founded in 1999 as the most hi-tech enterprise in automotive battery manufacturing in Iran. It is located at Oshtorjan industrial zone, Isfahan, Iran, and occupying a total land area of 65,000 m<sup>2</sup> with an investment in excess of 60 million USD. SBIC's annual production capacity is 5 million batteries, and it is planned to be increased further by introduction of a number of capacity alignment activities.

The manufacturing equipment are mostly fully automated and are made by the most renowned European battery manufacturing equipment suppliers, such as Digatron, Sovema, TBS, BM, La Pneumatica, etc. Usage of state-of-the-art equipment and first-class raw material has enabled SBIC to produce the highest quality lead acid batteries for automotive applications to European, Japanese and North American standards. SBIC is equipped to produce enough battery plates, lead oxide, distilled water and diluted sulfuric acid to support annual production of batteries. SBIC has also tooled enough plastic injection molding capacity to support approximately one hundred percent of its production needs without relying on any external sources.

Over the last 20 years, highly skilled engineers at SBIC have developed technical capabilities to be able to design and manufacture all types of batteries for OEM and after-market applications. SBIC's battery products include maintenance free (sealed), Euro-Kamina and Japanese N types for passenger cars and heavy duty vehicles in B20, B24, D23, D26, D31, G51, H51, E41, L1, L2, L3, L5, from 35 AH to 225 AH capacity and also EFB batteries which are used for cars with start-stop technology.



## CERTIFICATES of SBIC





**DIN** type

# BATIS

BATTERY

TYPE		Capacity 20 HR (AH)	Reserve Capacity (min)	CCA EN (A)	Max.Overall Dimension (mm)			Base Hold Down	Terminal Type	Terminal Layout
Box	Part Number				Length	Width	Total Height			
<b>DIN</b>										
<b>L1</b>	SMF54507	45	70	415	207	175	190	B3	A1	0
	SMF55090	50	79	470	207	175	190	B3	A1	0



[WWW.SEPAHANBATTERY.COM](http://WWW.SEPAHANBATTERY.COM)



**DIN** type

# BATIS

BATTERY

TYPE		Capacity 20 HR (AH)	Reserve Capacity (min)	CCA EN (A)	Max.Overall Dimension (mm)			Base Hold Down	Terminal Type	Terminal Layout
Box	Part Number				Length	Width	Total Height			
<b>DIN</b>										
<b>L2</b>	SMF55018	50	79	470	242	175	190	B3	A1	0
	SMF55559	55	88	505	242	175	190	B3	A1	0
	SMF56019	60	98	560	242	175	190	B3	A1	0



[WWW.SEPAHANBATTERY.COM](http://WWW.SEPAHANBATTERY.COM)



**DIN** type

# BATIS

BATTERY

TYPE		Capacity 20 HR (AH)	Reserve Capacity (min)	CCA EN (A)	Max.Overall Dimension (mm)			Base Hold Down	Terminal Type	Terminal Layout
Box	Part Number				Length	Width	Total Height			
<b>DIN</b>										
<b>L3</b>	SMF56638	66	110	595	278	175	190	B3	A1	0
	SMF57220	72	122	660	278	175	190	B3	A1	0



[WWW.SEPAHANBATTERY.COM](http://WWW.SEPAHANBATTERY.COM)



**DIN** type

# BATIS

BATTERY

TYPE		Capacity 20 HR (AH)	Reserve Capacity (min)	CCA EN (A)	Max.Overall Dimension (mm)			Base Hold Down	Terminal Type	Terminal Layout
Box	Part Number				Length	Width	Total Height			
<b>DIN</b>										
<b>L5</b>	SMF58439	84	146	775	350	175	188	B3	A1	0
	SMF59018	90	154	830	350	175	188	B3	A1	0
	SMF59485	94	158	860	350	175	188	B3	A1	0
	SMF60044	100	179	920	350	175	188	B3	A1	0



**JIS** type

# BATIS

BATTERY

TYPE		Capacity 20 HR (AH)	Reserve Capacity (min)	CCA EN (A)	Max.Overall Dimension (mm)			Base Hold Down	Terminal Type	Terminal Layout
Box	Part Number				Length	Width	Total Height			
JIS										
B20 (NS40)	SMF38B20L(NS40ZL)	35	52	305	197	129	227	N	A2	0
	SMF38B20R(NS40Z)	35	52	305	197	129	227	N	A2	1



[WWW.SEPAHANBATTERY.COM](http://WWW.SEPAHANBATTERY.COM)



**JIS** type

# BATIS

BATTERY

TYPE		Capacity 20 HR (Ah)	Reserve Capacity (min)	CCA EN (A)	Max.Overall Dimension (mm)			Base Hold Down	Terminal Type	Terminal Layout
Box	Part Number				Length	Width	Total Height			
JIS										
B24 (NS60)	SMF50B24L (NS60LS)	45	70	380	238	129	227	N	A1	0
	SMF50B24R(NS60S)	45	70	380	238	129	227	N	A1	1



[WWW.SEPAHANBATTERY.COM](http://WWW.SEPAHANBATTERY.COM)





**JIS** type

# BATIS

BATTERY

TYPE		Capacity 20 HR (AH)	Reserve Capacity (min)	CCA EN (A)	Max.Overall Dimension (mm)			Base Hold Down	Terminal Type	Terminal Layout
Box	Part Number				Length	Width	Total Height			
JIS										
D23	SMF65D23L	60	98	520	238	178	225	B4	A1	0
	SMF65D23R	60	98	520	238	178	225	B4	A1	1
	SMF75D23L	66	110	560	238	178	225	B4	A1	0
	SMF75D23R	66	110	560	238	178	225	B4	A1	1



[WWW.SEPAHANBATTERY.COM](http://WWW.SEPAHANBATTERY.COM)



**JIS** type

# BATIS

BATTERY

TYPE		Capacity 20 HR (AH)	Reserve Capacity (min)	CCA EN (A)	Max.Overall Dimension (mm)			Base Hold Down	Terminal Type	Terminal Layout
Box	Part Number				Length	Width	Total Height			
JIS										
D26	SMF80D26L(NX110-5L)	70	118	620	257	176	225	B4	A1	0
	SMF80D26R(NX110-5)	70	118	620	257	176	225	B4	A1	1
(N50)	SMF90D26L	75	128	660	257	176	225	B4	A1	0
	SMF90D26R	75	128	660	257	176	225	B4	A1	1



[WWW.SEPAHANBATTERY.COM](http://WWW.SEPAHANBATTERY.COM)



TYPE		Capacity 20 HR (AH)	Reserve Capacity (min)	CCA EN (A)	Max.Overall Dimension (mm)			Base Hold Down	Terminal Type	Terminal Layout
Box	Part Number				Length	Width	Total Height			
JIS										
D31	SMF75D31L(N70L)	70	118	620	306	175	225	B4	A1	0
	SMF75D31R(N70)	70	118	620	306	175	225	B4	A1	1
	SMF95D31L	80	138	660	306	175	225	B4	A1	0
	SMF95D31R	80	138	660	306	175	225	B4	A1	1
	SMF105D31L	90	158	760	306	175	225	B4	A1	0
	SMF105D31R	90	158	760	306	175	225	B4	A1	1
	SMF120D31L	100	179	860	306	175	225	B4	A1	0
	SMF120D31R	100	179	860	306	175	225	B4	A1	1

# BATIS

BATTERY

JIS type



**JIS** type

# BATIS

BATTERY

TYPE		Capacity 20 HR (AH)	Reserve Capacity (min)	CCA EN (A)	Max.Overall Dimension (mm)			Base Hold Down	Terminal Type	Terminal Layout
Box	Part Number				Length	Width	Total Height			
<b>JIS</b>										
<b>G51</b>	SMF155G51R	150	290	1010	510	222	232	B8	A1	3
	SMF155G51L	150	290	1010	510	222	232	B8	A1	4
	SMF185G51R	170	336	1135	510	222	232	B8	A1	3
	SMF185G51L	170	336	1135	510	222	232	B8	A1	4
	SMF200G51R	180	360	1215	510	222	232	B8	A1	3
	SMF200G51L	180	360	1215	510	222	232	B8	A1	4
	SMF205G51R	190	383	1265	510	222	232	B8	A1	3
	SMF205G51L	190	383	1265	510	222	232	B8	A1	4



WWW.SEPAHANBATTERY.COM



**JIS** type

# BATIS

BATTERY

TYPE		Capacity 20 HR (AH)	Reserve Capacity (min)	CCA EN (A)	Max.Overall Dimension (mm)			Base Hold Down	Terminal Type	Terminal Layout
Box	Part Number				Length	Width	Total Height			
<b>JIS</b>										
<b>H51</b>	SMF210H51R	200	407	1050	512	278	239	B8	A1	3
	SMF210H51L	200	407	1050	512	278	239	B8	A1	4
	SMF245H51R(N245L)	220	456	1100	512	278	239	B8	A1	3
	SMF245H51L(N245)	220	456	1100	512	278	239	B8	A1	4
	SMFH5122511111R	225	468	1110	512	278	239	B8	A1	3
	SMFH5122511111L	225	468	1110	512	278	239	B8	A1	4



[WWW.SEPAHANBATTERY.COM](http://WWW.SEPAHANBATTERY.COM)

TYPE		Capacity 20 HR (AH)	Reserve Capacity (min)	CCA EN (A)	Max.Overall Dimension (mm)			Base Hold Down	Terminal Type	Terminal Layout
Box	Part Number				Length	Width	Total Height			
<b>JIS</b>										
<b>D23</b>	D23060520101	60	98	520	238	178	225	B4	A1	0
	D23060520111	60	98	520	238	178	225	B4	A1	1
	D23066560101	66	110	560	238	178	225	B4	A1	0
	D23066560111	66	110	560	238	178	225	B4	A1	1
<b>N50Z</b>	65D26R	60	98	520	284	173	216	B8	A1	1
	75D26L	66	110	560	284	173	216	B8	A1	0
	75D26R	66	110	560	284	173	216	B8	A1	1

TYPE		Capacity 20 HR (AH)	Reserve Capacity (min)	CCA EN (A)	Max.Overall Dimension (mm)			Base Hold Down	Terminal Type	Terminal Layout
Box	Part Number				Length	Width	Total Height			
<b>JIS</b>										
<b>D31</b>	D31070620111	70	118	620	306	175	225	B4	A1	0
	D31070620111	70	118	620	306	175	225	B4	A1	1
	D31080660101	80	138	660	306	175	225	B4	A1	0
	D31080660111	80	138	660	306	175	225	B4	A1	1
	105D31L	95	169	820	306	175	225	B4	A1	0
	105D31R	95	169	820	306	175	225	B4	A1	1
	120D31L	100	179	860	306	175	225	B4	A1	0
	120D31R	100	179	860	306	175	225	B4	A1	1
<b>E41</b>	125E41L	120	223	1020	410	176	234	B8	A1	0
<b>G51</b>	155G51R	150	290	1010	513	222	217	B8	A1	3
	185G51R	170	336	1135	513	222	217	B8	A1	3
	200G51R	180	360	1215	513	222	217	B8	A1	3
	205G51R	190	383	1265	513	222	217	B8	A1	3
<b>H51</b>	210H51R	200	407	1050	512	278	239	B8	A1	3
	245H51R	220	456	1100	512	278	239	B8	A1	3
	H51225111131	225	468	1110	512	278	239	B8	A1	3

**BATIS**  
BATTERY

## Low Maintenance

TYPE		Capacity 20 HR (AH)	Reserve Capacity (min)	CCA EN (A)	Max.Overall Dimension (mm)			Base Hold Down	Terminal Type	Terminal Layout
Box	Part Number				Length	Width	Total Height			
DIN										
L1	54503	45	70	415	207	175	190	B3	A1	0
	55090	50	79	470	207	175	190	B3	A1	0
L2	55014	50	79	470	242	175	190	B3	A1	0
	55559	55	88	505	242	175	190	B3	A1	0
	56019	60	98	560	242	175	190	B3	A1	0
L3	56638	66	110	595	278	175	190	B3	A1	0
	57220	72	122	660	278	175	190	B3	A1	0

## Low Maintenance

TYPE		Capacity 20 HR (AH)	Reserve Capacity (min)	CCA EN (A)	Max.Overall Dimension (mm)			Base Hold Down	Terminal Type	Terminal Layout
Box	Part Number				Length	Width	Total Height			
DIN										
L5	58437	84	146	775	350	175	188	B3	A1	0
	59039	90	154	830	350	175	188	B3	A1	0
	59440	94	158	860	350	175	188	B3	A1	0
	60038	100	179	920	350	175	188	B3	A1	0



# BATIS

BATTERY

# LAYOUTS, HOLD DOWN AND TERMINALS

Battery Terminal Layout

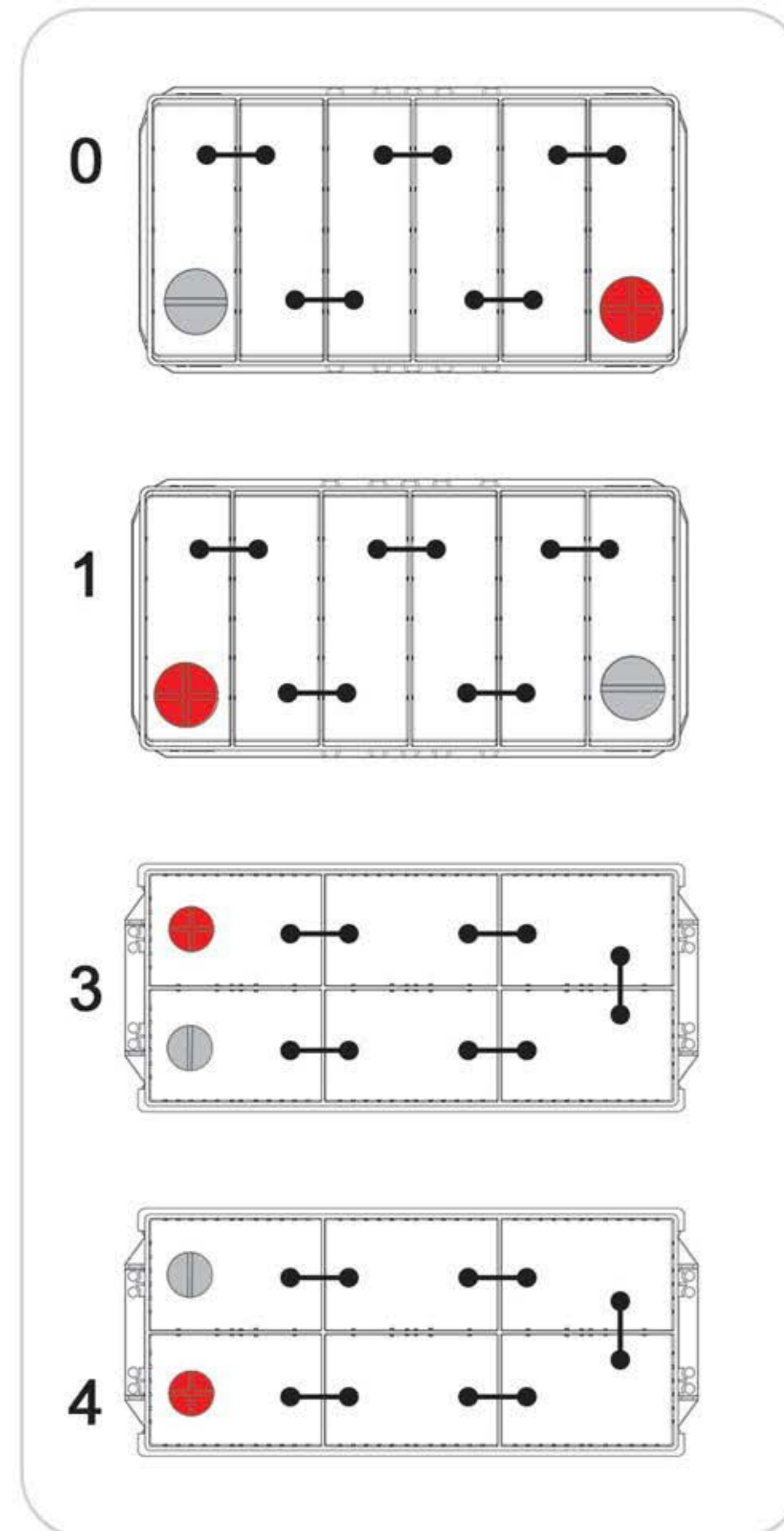

Battery Base Hold Down

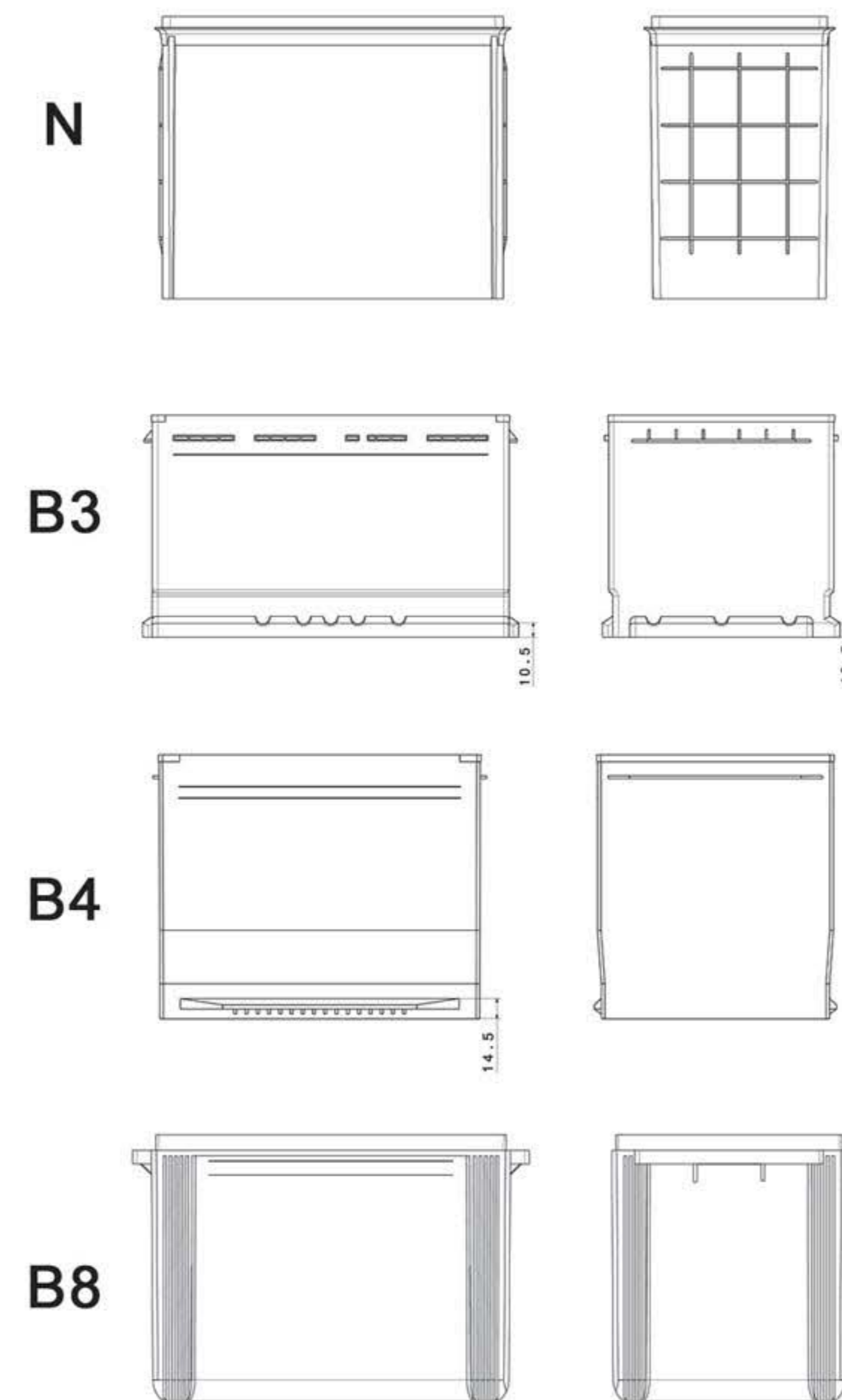

Battery Terminals

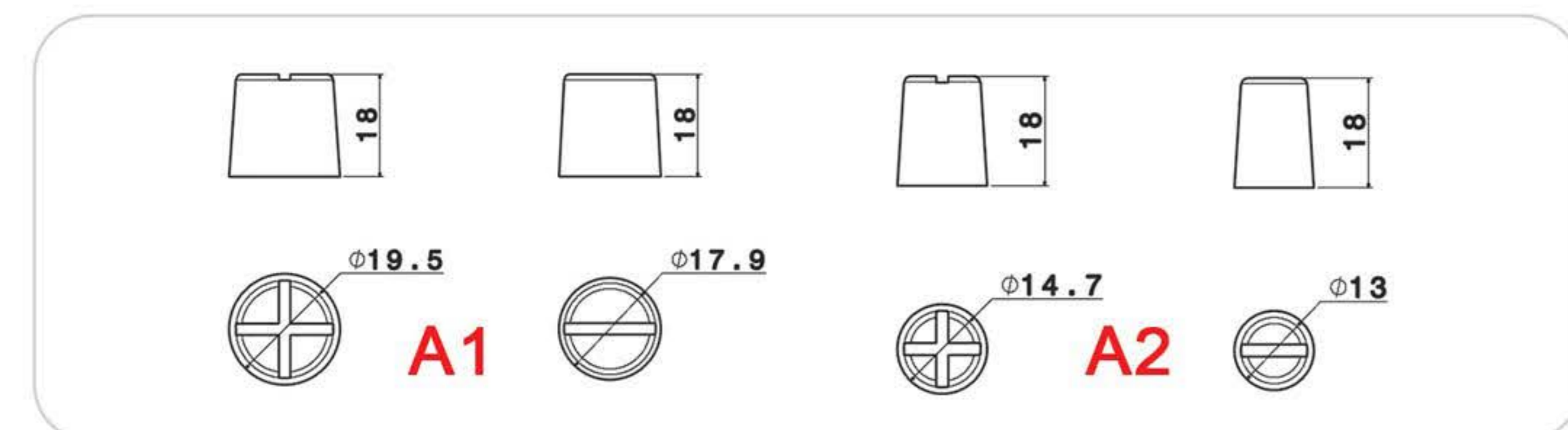

[www.sephanbattery.com](http://www.sephanbattery.com)

P.O.Box : 8 1 6 5 5 - 1 3 1 6

Office : (+98 31) 35053395

Fax : (+9831) 37608030

Email : [info@sephanbattery.com](mailto:info@sephanbattery.com)

[export@sephanbattery.com](mailto:export@sephanbattery.com)

@SEPHANBATTERY

